



Spud Speedway 2026 Track Rules

Important:

Please Make Sure to Read & Understand the Entire Rules Prior to Competing. A Racers Lack of Knowledge of the Rules is Not the Fault of the Speedway.

Rule Book Disclaimer

The rules and/or regulations set forth herein are designed to provide for the orderly conduct of racing events and to establish minimum acceptable requirements for such events. These rules shall govern the condition of all events, and by participating in these events, all participants are deemed to have complied with these rules. No express or implied warranty of safety shall result from the publications of or compliance with these rules and regulations. They are intended as a guide for the conduct of the sport and are no way a guarantee against injury or death to a participant, spectator or official. The race director shall be empowered to permit minor deviation from any of the specifications herein or impose any further restrictions that, in his opinion, do not alter the minimum acceptable requirements. No express or implied warranty of safety shall result from such alteration of specifications. Any interpretation or deviation of these rules is left to the discretion of the officials. Their decision is final.

Since it would be both impractical and impossible to list within the confines of any rule book all modifications, adaptations, and infractions that could be or would be illegal, it shall be understood for the purpose of rule book enforcement that only those items that are specified in this booklet are allowable and permissible. In addition, Spud Speedway holds the rights to fine, suspend, eject and/or withhold purse and points from anyone who violates these rules. Motorsports at all levels pose a risk to your wellbeing. Following the rules set for by Spud Speedway in no way guarantees or suggests your safety.

Point System For All Divisions

Feature winners in all divisions are awarded 100 points. Each position back is awarded two (2) less points than the previous position. Heat winners in all divisions are awarded 10 points for winning, and each position back receives two (2) points less than the previous position except 6th position receives one (1) point. No points are awarded for nonqualifier/consolation events in any division. Drivers must cross the start/finish and take the initial green flag and complete a full lap under green flag conditions during a feature race to receive feature points and purse. Points are awarded to the driver. One time per season a driver may have a substitute driver fill in. Points will go to the regular driver of that car for that one fill in race only. If more than one fill in driver is needed throughout the year, points will not be counted for those additional races. Substitute drivers must be brought to the attention of the Race Director prior to the event with the fill in drivers information. Purse money is paid to the person listed on the W9. Any other arrangements are between that person and the driver. In case of tie finishes where a clear and convincing winner cannot be determined, the purses and points for both or all positions in question will be pooled and divided amongst the drivers involved.

Any discrepancy in points or finishes must be addressed within 2 weeks of event.

Competitor must compete in minimum of 3/4 of the scheduled race events to qualify for any trophies.

Number Rules

1. All drivers must register on website. Numbers are not given/assigned until you are registered.
2. Number will be no more than 2 digits and one letter. Three digit numbers and fractions are not allowed. No new numbers will be issued with any number/letter combination.
3. All numbers must be kept in easily readable condition. If they are damaged in an accident, they must be fixed by the next race meet. Inability of the scorers to read numbers can result in the car being barred from competition until they are repaired to the satisfaction of head judge.

Line Ups

Heats :

All divisions will draw for heat starting positions. Car and Driver must be present at the time of drawing. Number of heats will be decided after draw takes place.

1. Cars will be lined up by order of draw position.
2. Any car not in lineup with 2 laps to go of the previous race will forfeit their spot and be put on the rear of their race.

Feature:

1. Cars will be lined up by order of heat finish. The top 3 from the previous feature will be lined up behind the rest of the group of drivers that qualified in the heats, regardless of where they qualified in the heats. Any driver who has not competed in the prior event in the selected division will start at the rear of the feature event, regardless of where they

qualified in the heats. Any cars disqualified from the most recent race event will start behind non-previous week cars. Drivers who do not qualify in the heats will start the feature at the rear of all.

2. In the event of a double feature caused by unusual conditions during the previous race meet, those cars and drivers not present at the postponed race meet will start at the rear of the make-up feature.
3. No car will be allowed to compete in more than one heat race under any circumstances. No qualified car will be allowed in any consolation race.
4. Any car not in lineup with 2 laps to go of the previous race will forfeit their spot and be put on the rear of their race.

Example: heat
qualifiers
top 3 from previous week
drivers not present event prior non-qualified

General Rules

Anyone who performs an act or participates in actions deemed by Spud Speedway Authorized Representative to be detrimental to the sport or to Spud Speedway including, but not limited to verbal abuse of any Spud Speedway official, the consumption of or being under the influence of alcoholic beverages in the pit area during a race meet, the use of or being under the influence of drugs in the pit area during a race meet, fighting - which is defined as making or attempting to make physical contact or reckless operation of a race car or other vehicle in the pit area shall be disciplined appropriately by track management.

Any person entering another pit area and causing conflict will be disciplined accordingly.

Anyone who has signs of alcohol and/or drug use about their person will be asked to leave the premises.

Any person using foul or abusive language toward any track official will be expelled without a refund.

Once a race vehicle is in the race arena, which includes the track, track shoulders, embankments or infield, and regardless of whether the racing action has been slowed or stopped, no driver shall exit his or her vehicle under any circumstances until authorized to do so by track officials or safety crew. **The only exception to this rule is if the driver is in immediate danger from fire, hot fluids or other significant threat to his or her safety or well-being.** Any driver disregarding this rule will subject to immediate suspension or other penalty imposed by track management.

Social Media is a great tool for marketing our sports collectively and can help us find new fans and racers for you to compete with at the track. We ask for everyone's cooperation in not making negative comments towards the track, fellow competitors, or track officials. We are all in this together and want to see these events succeed and spreading negativity is not helpful to any of us and make you look bad to your fans, family, and sponsors as well. If social media issues arise you will be asked to remove them and receive a warning for the first offence. Beyond that warning it will be the sole discretion of the tracks officials to decide if fines, suspension, or banning a competitor from the track is appropriate to the situation. These rules also apply to the staff of the speedway as well. We fully understand the hard work and passion that everyone puts into what we are all doing, but no one on social media will be able to solve your issues, please remember if you have an issue the best way to address it is to bring it to the race director's attention. We appreciate everyone's cooperation with this important issue.

All new racers/rookies will be required to place a 6" wide yellow tape stripe on the rear bumper of the car to help identify new racers to other racers.

All race cars will be mandated to display our track division sponsors sticker to be eligible to receive any payouts. Stickers will be provided by the track.

Any cars left at the race track for more than 7 days after conclusion of the racing season will be removed at the car owner's expense.

PIT RULES

1. All persons in the pit area are under the control of the Pit Steward. Disobedience of the Pit Steward's directives is cause for expulsion from Spud Speedway property. Speed limit in the pit area is 5 mph for all vehicles. Any speeding, pin wheeling or other such reckless conduct with any vehicle in the pit area will not be tolerated.
2. Everyone in the pit area must sign in at the pit gate and pay full admission price. Anyone under the age of 18, here after referred to as minors, must present a properly completed Spud Speedway Minor Release Form for the current year to the pit ticket takers and proof of paid admission before entering the pit.
3. Any driver that is under the age 18 of must have a valid and legal learners permit or driver's license. Any minor that is interested in racing must be approved by management. Do not assume because you want to race that you can. ALL minor drivers must be accompanied in the pit area by a legal parent.
4. Only vehicles towing a stock car are allowed in the pit area. Personal Vehicles are NOT covered by any insurance in Restricted Areas.
5. Any person who has signs of liquor, drugs or firearms about him/her during a race meet shall be removed from the premises for the remainder of the event. If the person with the issue is directly connected to a race team, the team may lose points, payouts, and also be asked to leave depending on the circumstances and is the decision of the track officials.
6. No racecar will carry more than one person at any time while it is in motion in the pit area or on the track. The only exception is during "Ride with your favorite driver" while vehicle is on the racetrack.
7. No driver, owner, or mechanic will have any claim for damages, expenses or otherwise against track officials, owners, operators or promoters for disqualification, damage to car or driver, and agree that all conditions are safe when they participate in a meet.
8. If you are involved in an accident involving an injury to yourself, advise the tower or pit gate immediately so that the necessary insurance reporting will be accomplished. Any person who refuses or does not seek medical treatment by the official medical team at the track forfeits any and all insurance protection.
9. **PIT TOWER ATTENDANT MUST BE NOTIFIED OF ANY CHANGE IN DRIVERS DURING A RACE MEET AND MUST BE NOTIFIED OF SAID CHANGE PRIOR TO THE RACE MEET.** If this is not done prior to the running of the race, the

driver/owner shall forfeit all purse, points, and position for the race in which the offense took place. Offending cars and/or drivers will be barred from the next meet. There will be no exceptions to this rule. If a car is disabled, the driver is eligible to borrow a different car registered to race in the same division. Pit Tower Attendant must be notified of the change as noted above. If the borrowed car is determined to be illegal at the conclusion of the race, the driver borrowing the car and competing with it will lose any points or purse for that race meet only.

10. Management will review all disputes and infractions and reserves the right to decide on any disciplinary actions to be taken. Decisions will be made, and the offending parties notified prior to the next regularly scheduled meet.
11. Any incident not covered by these rules may be decided upon by management and made a rule for the rest of the season.
12. Disposal of tires and oil is the responsibility of the driver.

Speed limit in the pit is 5 M.P.H. for all vehicles.

One warning, any repeat offenders will be penalized. First warning will be announced over the PA system. Subsequent offences will be verbally from a track employee or subcontractor.

Racing Rules

1. Once a car is on the racing surface, it is under the control of the flagman and race director. Any disobedience of their directions or decisions may be cause for disciplinary action.
2. Any car assisted by the wrecker to get going will go to the rear. Officials have the discretion to return a vehicle to its previous position when the vehicle becomes stuck in the sand/grass when avoiding an accident.
3. Any car spinning out by itself causing a restart will be placed at the rear of the line-up at the restart. Cars purposely or intentionally accelerating during a spinout and endangering others in the process are subject to disqualification from that event. Any car spinning out by itself three times in the same race is subject to disqualification from that event.
4. There shall be no restart of an event because of a spinout or accident if, in the flagman's opinion, the track is not blocked and the driver is not injured or in immediate danger.
5. Any car leaving the line-up or going to the pit area must rejoin the field at the rear of the pack. **In the event of an accident all unauthorized persons must remain in the pit area.** Violation of this rule may cause disqualification of the car and/or driver for the remainder of the event. Owners are responsible for stressing this rule to their crew. "I didn't know" will not be accepted for an excuse - this is for your own safety to allow trained medical personnel unrestricted access to you in the event of an injury.
6. All feature and championship events shall be run the full number of laps regardless of restarts barring unusual conditions such as rain, darkness, or the lateness of the hour. Feature events shortened by unusual conditions will have been completed under green flag conditions. If the event is called while being run under caution, the last full lap scored will be used to determine finishing positions. To be in final results the car must be on the track, others will be scored according to the number of laps they completed. Final results will be determined by track officials.

7. If in the event of an uncontrollable circumstance that a race cannot be completed in full that race will be considered official if the race is past the half way mark. If not past half way then the race will be restarted the following event. Any cars not in attendance at the originally scheduled event will have to start at the rear of the make- up feature.
8. Rough riding, excessive track use and unsportsmanlike conduct of any kind is not permitted. Arguing with track officials and displays of temper with an automobile in front of the grandstand area are prohibited and will be dealt with severely. Drivers and/or crew coming up to the flag stand or scorers tower uninvited onto at any time will be cause for disciplinary action. Complaints from drivers will not be heard in front of grandstand. Drivers will disengage from the discussion with the track official when told to do so or be subject to disqualification from the event.
9. Entrance from the pit area to the track is on the third turn. Exit from the track to the pit area is on the second turn. Violators are subject to disqualification from an event.
10. Any car on the racing surface, which is deemed by the Race Director or the Flagman to not be competitive, may be asked to leave the racing surface by display of the black flag. If the car can again compete at racing speeds, it will be allowed to re-enter the race at track official's discretion. Cars must be able to maintain a pace of at least 2 seconds off the lead cars time.
11. Pole car has choice of inside pole or outside pole on restarts in both heats and/or features after original lap is completed. If the first lap is not completed, the line-up goes back to a complete and original lineup. If a car or cars cause a caution during the initial start, track officials may use their discretion to put the car or cars responsible to the rear. Pole drivers have the responsibility set the pace for the start or restart. These drivers will not accelerate on starts or restarts until their cars are exiting turn 4 and have passed the white line on the track in turn 4. Any car deemed to have jumped a start will be docked two positions per car passed at the next caution flag. If no caution flag is waved then the penalty will be assessed at the completion of the event.
12. A driver or car owner may request to meet with any track official at the conclusion of the race meet provided the request is made to the Pit Steward within 15 minutes of the completion of the race in question.
13. No driver may change cars nor may any car change drivers during the running of a particular race.
14. All cars must be self-starting in the pit area prior to participation in the race meet.
15. Driver and track personnel shall not attempt to fix any car on the racing surface.
16. All lapped cars in the feature will go to the rear of the field inside 10 to go.
17. No cell phones of any kind allowed in the racecars at any time under the control of the driver. Anyone caught using a cell phone in their car will be disqualified from that event.
18. All divisions will be required to have transponders. Transponders will be available through Spud Speedway Inc. for purchase or to rent on a weekly basis. If you already own a transponder, please record the number on your driver's form when filled out for the season. Transponders that are not installed in the specified location and do not read properly will not be the track's responsibility or issue. If your transponder doesn't read, you will not be scored.

Transponders

1. Transponders are required for all divisions.
2. Transponders may NOT be shared on different cars on the same race day.
3. Transponders need to be registered when registering and drawing for position.
4. Transponders MUST be on for practice. If you don't want your lap times or other stats shared during practice there is a way in the account settings to shut those off, but the transponder must be on the car to make sure it is working. If it is not working you will not be scored in the race.

Attention All Divisions: Transponders must be on your car for all Practices, Heats, and Races. Any car that does not have a transponder on your car during a practice session will be sent to the pit area to have transponder put on. Any car that refuses to leave the racing surface to have a transponder placed on the car will not be allowed out during the next practice. If it is the last practice, and you refuse to leave the race surface to have a transponder placed on your car, you will only receive half points for the heat race. Any car that does not have a Transponder for the Heat or Feature Race will not be scored.

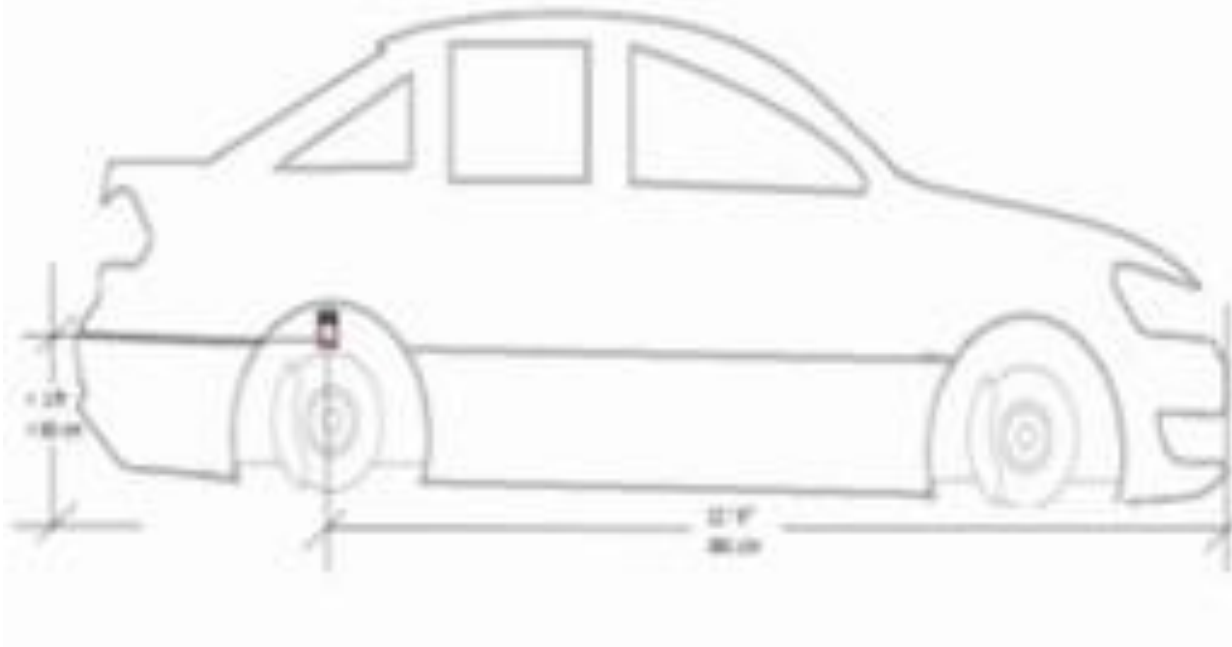

Figure 1 (12'6" or 381cm front to rear measurement. Height is <2' or <60 cm)

Raceceivers are mandatory for all regular race divisions. They can be purchased without headphones or with headphones, plus sales tax. These will be available to visiting racers for rent for \$15 per race event. Rentals are for visiting cars only. These can also be used at other tracks that utilize this same technology, such as Speedway .

Flag Rules

Green Flag:

The green flag signals the start or re-start of a race. On an original start, cars must remain in their position until they have crossed the start/ finish line. Any car getting out of line or passing before said start/finish line on the original start of a race will be penalized two positions for each car passed. On restarts, passing is allowed immediately after the green flag is displayed. Passing prior to the display of the green flag will result in a two position per car passed penalty. All penalties will be assessed at the conclusion of the event or at the next caution after the infraction, whichever occurs first.

Yellow Flag:

The yellow flag signals caution. When the yellow flag is displayed, all cars must stop racing immediately and fall into single file in the position they were in when the flag was displayed. Cars should circle the track slowly until notified by track officials of any change in position. The flagman will notify scoring regarding the reason for the yellow and which car(s) caused the yellow flag to be thrown. These cars will be sent to the rear of the line-up. Cars will be lined up for the restart according to their scored position on the last completed green flag lap, except for those cars designated to go to the rear of the lineup. A lap is considered completed when all cars competing on said lap have crossed the start finish line. Any car going to the pit area while under caution will restart at the rear of the line-up. We do not race to the yellow flag. In the event of a yellow on the final lap all cars must maintain their running position and safely cross the line. The running order will be (frozen) at the time of the yellow flag and the race will be considered complete.

Red Flag:

The red flag means the race must be stopped immediately regardless of the cars position on the track. Red flag laps are not scored. After stopping, wait for the light to return to yellow or for the flagman to signal that it is safe to move. Cars should proceed to turn three and wait for a line-up.

White Flag:

The white flag signals that a driver is entering the final lap of a race. The next flag will be the checkered flag unless a red flag is displayed because of an unsafe condition between the cars racing the final lap and the start/finish line.

Checkered Flag:

The checkered flag means the race event is over. The first three cars, as determined by distance run, should proceed back to the start finish line for verification. Once released by the officials on the track, the first three cars must proceed directly to the technical inspection garage before returning to their pit areas. Failure to do so may result in disqualification and loss of purse and points for that meet.

Black Flag:

The black flag is the consultation flag. When the black flag is displayed to a car, the driver must leave the racing surface for the pit area immediately. Scoring will immediately stop scoring the car when the black flag is first shown. The driver will be informed in the pit area of the reason for the black flag. The black flag may be displayed for an infraction of the rules, in which case the driver is disqualified from further participation in that event only, and loses all points and purse for that event. If the black flag is displayed for a mechanical problem deemed by track officials to be hazardous to either

the driver or other competitors, the car will be allowed to re-enter the event if the car is repaired. No purse or points will be withheld from a driver black flagged for mechanical problems.

Passing flag (blue flag with diagonal yellow stripe):

Shown to a driver who is about to be put a lap down by the leaders. Informs a driver that a faster car is approaching and that the driver should move aside to allow one or more faster cars to pass.

Half way: Will be shown with the yellow and passing flags crossed in an x.

Safety Rules All Classes of Racing

Batteries:

1. Battery must be mounted within the car and must be securely bolted to the floor, mounted in a battery box and covered to prevent spillage. Batteries and fuel cells cannot be mounted in the same compartment. .
2. Fire Extinguisher: All cars in all divisions must carry an operative 3# minimum fire extinguisher with gauge that is within reach of the driver. All extinguishers must have a metal quick release-mounting bracket. No plastic brackets, tape, wire or other makeshift devices will be allowed. Also -1 A fire extinguisher of a minimum 5 lb. must be clearly visible in the team's pit area. Extinguisher must display car number on the side.
3. Window nets: Window nets are required in all divisions and must be fastened to the roll cage and must be quick release with a seat belt type fastener. Window nets must be securely fastened at all times when a car is on the racing surface.
4. Helmets: All helmets must be of racing or motorcycle type and must be Snell approved. Helmets must be worn at all times when a car is on the racing surface.
5. Drive shaft: A drive shaft safety loop or under sling is required within 12" of the front universal joint. The drive shaft must be painted white.
6. Brakes: Four wheel brakes in proper working order are mandatory at all times. Brake shoes or pads must be mounted and operating on all four wheels
7. Overflow can: A four (4) quart minimum overflow can connected by hose to the radiator and mounted in the engine compartment is mandatory.
8. Bumpers: Bumpers must be welded to the frame for safety and must be stock in appearance. NO BATTERING RAMS. Rear bumper/bumper covers strapped to body or frame.
9. Doors: All doors must be welded shut.
10. Fenders: Fenders may be trimmed for tire clearance only. All trimmed edges must be rolled to eliminate rough edges.
11. Hood: Hood and trunk must be securely fastened down at all times. Enforcement of this rule is at the discretion of the flagman/race director, and his decision is final.

12. Firewall: All cars must have a steel firewall of at least .22 gauge thickness between the engine compartment and the passenger compartment as well as between the passenger compartment and the trunk area containing the fuel cell.
13. Fuel Cell: All cars must have a fuel cell with foam inside mounted in a box of no less than .22 gauge steel. All fuel cells must be securely fastened to the vehicle in the trunk area and have a minimum of 8" ground clearance. Fuel cells must have a vent hose with check valve. Vent hose must extend below fuel cell when car is in the upright position.
14. Glass: A full windshield of either safety glass or Lexan™ is required in all divisions. If a windshield is lost during a race meet, the driver may continue to race if he wears goggles or a full face shield and installs at least 1/4" mesh screen over the windshield area. Cracked or broken windshields must be cleared by the Safety Committee before a car will be allowed to compete.
15. Steering Column: Steering columns must be collapsible or have at least two (2) universal joints. Steering box "rag" joint and heim joints supporting steering column are not considered universal joints. Center of steering wheel must be padded. All divisions must have quick disconnect steering wheels.
16. Roll Cage: A full roll cage of four uprights joined at the top by a complete loop is required for all divisions. Front hoop and supporting bracing is mandatory. Front hoop is optional in Strictly Street Division. All piping must be at least 1 1/2" O.D. steel and welded 360 degrees. No galvanized pipe allowed. No threaded fittings or flattened ends will be allowed. Three (3) door bars on driver's side are mandatory, with proper bracing and gussets. Two (2) door bars with proper bracing and gussets are required on the "Passenger" side, with three strongly recommended. These bars may either follow the contour of the door or be square with front and rear uprights. A complete hoop is required overhead with at least one bar either diagonally across or front to rear. At least two braces must extend behind the rear uprights to a point on the frame at least three feet back. Bracing extending into the trunk area to protect the fuel cell is recommended. A horizontal bar between the two front uprights in the dashboard area is recommended. A driver side vertical "vent window" brace is recommended. A plate of at least 1/8" thickness is required to be welded and gusseted between the door bars and the body panel on the driver's side. The plate should be located so as to protect the driver from foreign objects that may pierce body panel.
17. Seats and seat belts: aluminum seats are required in all divisions (with exception of Modified Enduro Class). Seats must be mounted attached to the roll cage. Seat belts must be airplane type quick release and capable of withstanding 3,000# body block test. The seat belts must be attached at two separate points on the roll cage equal distance from the center of the seat back and no less than twelve (12) inches apart. Seat belt bolts must be mounted with the correct size bolts as recommended by the manufacturer of belt harness. Typically 7/16" grade 8 bolts. Bolts must be aligned so that the direction of stress will be in direct line with the pull of the seat belt. If belts are attached to a steel plate attached to the frame, the plate must be a minimum of 1/4" thick. Shoulder straps are mandatory and must be securely fastened to the roll cage behind the driver's seat or to a 1/4" plate welded to the roll cage behind the driver's seat. Sternum and submarine (crotch) belts are highly recommended. Seat belts and helmets must have a date of manufacture not more than four years old. 5-point safety harness required; harnesses must have a date of manufacture not more than six years old unless approved by Safety Team.
18. Clothing: All drivers in all divisions must wear an approved long sleeve fire retardant racing suit and racing gloves at all times when the vehicle is on the racing surface. Flame resistant shoes are MANDATORY

This includes test and tune sessions. Racing suits must be free of rips, tears and holes, and have a date of manufacture of not more than four years old, to be checked a few times a year by the safety committee. Fireproof racing suits and racing gloves are mandatory in ALL divisions.

19. An SFI 3.3 rated neck collar will allowed. It will be the MINIMUM acceptable neck support device that may be worn. The current HANS device will still be the recommended neck safety device.
20. The HANS device tether straps will be inspected. While not mandatory at this time the straps are recommended to be replaced either every 5 years or in the case of hard impact then immediately.
21. Any jack points protruding through the body panels must be approved by the Safety Committee. Safety Committee approved 1" rub rails mounted flush with body panels allowed in all divisions.
22. No boxing of the passenger side of the interior will be allowed if it prohibits the easy removal of the driver through the passenger side of the car.
23. All vehicles must have front and rear tow hooks made of 1/2" rolled steel and installed as a vertical loop. The track and its tow crews will have no responsibility whatsoever for damage resulting from towing a disabled vehicle from the racing area.
24. The Safety Committee has the right to disqualify any car from competition based on any infraction of the safety rules. Any infractions must be re-inspected before that car will be allowed to compete. The Safety Committee is responsible for the placement and visibility of numbers.
25. No anti-freeze in cooling systems. Water and KEEP KOOL™ quick cool only.
26. Any weight added to vehicles must be mounted securely in place and painted white and have the car number on it.
27. All air bags must be deactivated.
28. Tow hooks are required front and rear. They must be attached to any solid structure in the bumper area (i.e. bumper impact bar support). Three or four links of chain welded to the bumper mounts is sufficient. **ALL CARS MUST HAVE FRONT AND REAR TOW HOOKS OR CHAINS EASILY ACCESSIBLE TO WRECKER CREWS.** No Tow hooks means no racing.

The track and its tow crews will have no responsibility whatsoever for damage resulting from towing a disabled vehicle from the racing area.

All drivers in all divisions must wear an approved long sleeve fire retardant racing suit and racing gloves at all times when the vehicle is on the racing surface. This includes test and tune sessions. Racing suits must be free of rips, tears and holes, and have a date of manufacture of not more than four years old, to be checked a few times a year by the safety committee. Fireproof racing suits and racing gloves are mandatory in ALL divisions. No Mechanics Gloves allowed.

General Technical Rules

1. All cars must start the race meet with all body panels in place. Body components found to be illegal must be replaced before that vehicle will be allowed to compete. Removal of an illegal component once the race meet has begun does not make that car legal.
2. No equipment will be considered as having been approved by reason of having passed through inspection undetected. Any equipment which does not meet specifications or tolerances may not be eligible for approval.
3. All cars being weighed for compliance with technical rules will be weighed with each wheel centered on a scale, the driver belted in the seat and sitting in an upright position with his/her helmet on or resting in his/her lap.
4. Post race tech inspections will be held with **ONE** representative of each of the top 3 finishing teams and the technical inspector involved. There will be a list of weekly inspectable items put forth by the tech director each week. All other rules for that class will be placed in a bucket and one additional random item will be chosen to check. Rules are written in black & white and should be clearly followed in all circumstances. If a question arises or a judgement call is needed to be made the tech director may choose to have the 2 race teams inspection person (the 2 not on the team's car in question) vote on the proper action to be taken. If there is a tie the tech director would be the deciding vote. At all times the tech director has the right to decide on any given issue if he or she sees fit, based on the situation.
5. Spud Speedway reserves the right to all final decisions on the interpretation of any rule or rules. Decision of track management will be final.
6. Spud Speedway reserves the right to confiscate any illegal parts found during any inspection.
7. Anything that is not specifically shown in these rules will be considered illegal. Please contact the tech director for clarification. **DO NOT ASSUME!**

THE TECH COMMITTEE RESERVES THE RIGHT TO ADD OR SUBTRACT WEIGHT AT THEIR DISCRETION FOR EACH ITEM NOT MEETING SPUD SPEEDWAY SPECIFICATIONS.

Tech has the option to give last place points and loss of award money to a car/driver that has an infraction to the rules that would not warrant a disqualification.

THE TECH COMMITTEE MAY ADD OR SUBTRACT WEIGHT IN THE FAIRNESS OF COMPETITION

Any alteration to any part of the car not specifically covered in these rules must be cleared with the technical inspector or it will be considered illegal. In other words, **IF IT DOESN'T SAY YOU CAN DO IT, YOU CAN'T.**

Any specification not covered by these rules may be decided upon by tech management and made a rule for the rest of the season.

Motorsports at all levels pose a risk to your wellbeing. Following the rules set for by Spud Speedway in no way guarantees or suggests your safety.

Teardowns

1. Management or the Technical Committee may request a technical inspection of any car at any time. Refusal to submit to technical inspection is considered out of stock and will cause loss of purse and all accumulated points. **Top three finishers in each feature must go directly from the track to the inspection area. If you go to your pit area first, you will be considered illegal and disqualified.** Management reserves the right to exclude anyone from the inspection area at any time. Only those persons approved by the Technical Inspector are allowed in the inspection area.
2. When there is a specific question by other competitors in the same division regarding the legality of a particular part of a particular car, the following procedure must be followed in order to have the Tech Committee inspect that car:
 - a. One driver/car owner competing in the same race meet as the car in question must notify the Pit Steward at least 15 minutes before that race that they desire an inspection of that particular part of that particular car. The driver or owner requesting the inspection must present \$500.00 and a technical inspection request form
 - b. If the car in question is found to be illegal, the money will be returned to the petitioner(s) and the car will be disqualified from the race meet. If the car is found to be legal, the money will go to the owner of the car in question minus the cost of the technical inspection. Only one (1) petitioner will be allowed to observe the inspection.

Drivers of cars found to be illegal following an inspection by the Technical Committee will lose all points accumulated during that race meet. Any purse monies won during the race meet at which the car was found illegal will be forfeited. Tech has the option to give last place points and loss of award money to a car/driver that has an infraction to the rules that would not warrant a disqualification.

3. Any car found to be in violation of technical rules may be subject to reinspection before it will be allowed to compete again. For the purpose of rule enforcement, the term "STOCK" will mean of original equipment manufacturer (GM, Ford, Chrysler, etc.) Any aftermarket parts are allowed at the discretion of the Technical Inspector.

Spud Street Stock Rules

Approved Models:

1. Cars must be American made passenger production six (6) or eight (8) cylinder cars 1970 to present. All chassis must maintain stock wheelbase for frame utilized. Cars must be street legal for make and model. No convertibles, Vans, Station Wagons, or pick-up truck type vehicles, Front or rear wheel drive allowed. No four wheel drive vehicles. Minimum wheelbase of any car 101".
2. This division is for full framed perimeter chassis OR unibody RWD framed cars. If a car has been modified in any way from stock, it will need to be approved by the Tech Department and Track Management. Cars outside of a stock perimeter chassis may be approved or denied based on the level of deviation. Cars that are approved may also have additional rule adjustments applied to them. Rules adjustments would be meant to equalize the cars to ensure a fair and competitive race. Typical adjustment examples are as follows, but not limited to:
 - a. Weight adjustments (weight will need to be mounted ahead of the bell housing, minimum 12" forward of the rear axle centerline, mounted no higher than the top of the frame rail, and securely bolted and non-movable. A typical weight adjustment would be 100lbs)
 - b. Left side percentage of 1% less than the standard rule
 - c. Tire Stagger 1" less than the standard perimeter chassis
 - d. Shocks – no bump stops, packers, or suspension limiting devices

THESE ARE ALL JUST POTENTIAL RULE ADJUSTMENTS DEPENDING ON THE LEVEL OF DEVIATION THAT A CAR MAY HAVE. THESE RULES ARE 100% DECIDED UPON BY TRACK TECH AND MANAGEMENT, IF THEY ARE DEEMED NECESSARY TO CREATE A FAIR AND COMPETITIVE RACING ENVIROMENT. THIS RULE DOES NOT MEAN STRAIGHT RAIL OR TUBE CHASSIS CARS ARE ALLOWED TO RACE IN THIS DIVISON. THIS IS A STREET STOCK CLASS.

Body:

1. Stock Appearing Duraflex™ and AR Body™ are allowed. Late model body allowed. Body may be interchanged with chassis, but must be of same make, example, Chevy body on Chevy frame Etc. Stock after-market panels allowed per stock specifications. Rest of body must match model of roof, including front fenders, must be stock appearing. only exception is front and rear stock type vehicle plastic bumper covers of any model allowed.
2. Body panels may be fabricated out of aluminum without penalty as well.
3. No dirt or wedge type bumper covers.
4. Floorboards must be stock on driver's side. Passenger side may be fabricated but must remain fully closed in and of similar height to floorboard. 25lb penalty for not having complete factory floorboard in drivers compartment from seat to firewall, from rocker panel to center floor hump (trans/driveshaft tunnel).
5. Raised tin fabrication allowed for exhaust clearance.
6. Firewalls may be fabricated from .22 gauge steel but must remain in stock location.
7. Fabricated firewalls receive a 25 lb. weight penalty.
8. Rocker panels may be removed but must be replaced by metal or aluminum fabrication that keeps interior of car enclosed.
9. Doors may be replaced with .22-gauge steel.
10. Hoods may be replaced with fiberglass or aluminum. Air Breathers cannot protrude outside of hood. Hood cannot be cut open. Additional hood scoops allowed but only opened in the rear, No Air Induction Scoops ALLOWED.

11. Rear deck lids must be in place and of stock length and installation.
12. Inner body panels may be removed.
13. Spoiler 5" x 60". No side boxing. Spoiler cannot extend past top of bumper cover. Max spoiler height 43" from ground to top of spoiler. Modifications to the rear body is allowed to achieve this height only. No lengthening of tail pieces or fender shelving added, no more than 3" shelving on each side or any other body modifications allowed. Maximum length for any Gen Camaro 37" from axle center to spoiler mount location on rear bumper. Maximum length for Monte Carlo 40" Maximum quarter panel height 38" Roof Height minimum 48" 14. No panning of any kind to under side of car or airflow devices except for what is allowed in the rule book.
15. All cars must start the race meet with all exterior body panels in place.
16. Vent windows allowed maximum 12" length

Frame:

1. Must have a four-point roll cage but a full roll cage is suggested. Square tubing allowed from center of rear-end back, must be in stock position. Roll cage cannot be set back any closer than 24 inches from center of rear end. Wheelbase must match suspension for year make and model of chassis. Center section of chassis may be tied together underneath according to tech specs.

Weight:

1. Must weigh a minimum of 3,000 lbs. with driver in the car. Maximum Left side weight is 54% (54/46). All cars being weighed for compliance with technical rules will be weighed with each wheel centered on a scale, **the driver belted in the seat and sitting in the upright position with his/her helmet on or resting in his/her lap.**
2. Fabricated firewalls receive a 25 lb. weight penalty with 53% left side weight
3. Any car with weight penalties runs at 53% left.
4. All cars must meet weight and ride height rule AFTER race NO allowance for fuel burnoff, ect.
5. Spud Speedway reserves the right to add any amount of weight to any location on any car to keep this class competitive and fun, Weight will be supplied and installed by owner. Installation must meet tech approval.

Suspension:

1. Front and rear jacking bolts allowed.
2. 4th generation Camaro running coil over struts on car must have spanner nuts and must be doubled up so they are locked.
3. Upper control arms on rear end may be re-drilled.
4. Lower rear control arm mounts may be moved up or down, must remain stock.
5. Stock replacement tubular upper A-frames allowed with a non-adjustable ball joint only, mounted in stock position on stock mounts 1" variance from stock length allowed.
6. Lower A-frames must remain stock make and model.
7. Stock sway bars only in stock location, stock frame mounts may be adjustable on one side. Max diameter 1 3/8". Struts must be mounted in stock location.
8. No high performance, adjustable or "take apart" shocks allowed, no split valve shocks.
9. Minimum height of any part of the body or frame must be 5" measured from the lowest part of the frame. Will be measured with driver OUT.
10. All other suspension parts must be stock for make.
11. Rear leaf spring cars may have adjustable shackles no longer than 6", lowering blocks allowed non-adjustable.
13. Panhard bar and trailing arms allowed on full frame metric cars.

14. Weld on brackets allowed for trailing arms, panhard bars and shock mounting.
15. Three (3) link rear suspension with stock ends ALLOWED.
16. Non-adjustable MUST be welded solid.
17. No bump stops or suspension limiting devices allowed.
18. Leaf Springs MUST be steel. Strut shaft size 32mm MAX.
19. Shocks must be steel and non-rebuildable retail value of \$125.00

Wheels:

1. May use aftermarket steel wheels.
2. Track width no more than 66" for wheelbases of up to 108". Track width no more than 67" for wheelbases longer than 108".
3. All track widths will be measured from center to center of the front tires.
4. Steel racing wheels max eight (8) inches wide as measured from bead to bead
5. No Wide 5 Wheels.

Tires:

1. American Racer 7" 225 SH or H track tire, EITHER SIDE with any combination Mandatory 4 tire purchase from the track to compete for season points championship.
2. Tires must be purchased from the authorized tire representative. Once Tires leave the tire sales area ABSOLUTELY NO RETURNS.
3. No chemicals may be used while mounting tires to rims.
4. Fenders may be trimmed to allow for tire clearance.. No flaring of fenders and all cuts made must be smooth and rolled under to avoid cutting a competitor's tire.
5. **Absolutely no tire softener.** If tech suspects tire softener all tires will be dismounted and confiscated, and you will be disqualified. If protested a sample of the tire will be sent out for evaluation. The driver will be responsible for all costs of the testing if it is found positive.
6. If any car does not meet these above rules weight will be added or penalty will be accessed.

Engines:

1. 602 crate engines allowed with stock specs. Crate engines must be sealed. Sealed engines will be subject to verification of the seal numbers in lieu of any teardowns unless the tech director sees something in question that would require a full teardown.
2. GM LS engines, Iron block 4.8 or 5.3 with stock cathedral port heads only. MDS 6014 ignition box, .550" lift cam.
3. Minimum, 13 ½" crank height measured from ground to center of bolt.
4. GM max engine size 350 plus .060 over . Ford max 351w plus .060 over Chrysler 360 plus .060 over.
5. Engine block cylinder heads must be cast iron and O.E.M. stock.
6. Crank shaft must be cast or forged. No modifications or lightening.
7. Minimum two valve relief pistons allowed.
8. Stock steel connecting rods or aftermarket stock replacement.
9. Racing oil pan allowed.
10. Cam shaft must be hydraulic flat tappet only. Stock lifter bore. Max. lift .460 at the valve. Stock type rockers 1.5 Ratio. Cylinder heads must be O.E.M. castings straight plug. World product head #4361 will be allowed.
11. Vortec heads allowed.

12. Max valve size 1.94" intake 1.6" exhaust. Intake must be stock O.E.M. cast iron 2 barrel or 2101 or 2116 aluminum ONLY may be used. ONLY 602 crate motors can run crate intake. Max compression 10.2:1.

Carburetors:

1. Stock Holly™ 4412 on built or 602 crate.
2. No VDL's.
3. No changeable air bleeds.
4. Only modifications are the removal of choke plate assembly, jet change, power valve change and accelerator pump change.
5. Rochester™ (2) two barrel allowed. Must use Mr. Gasket™ # 1929, #1937 or #1933 adapter ONLY.

Fuel Cells:

1. May be mounted through trunk floor and securely fastened to the car. Fuel Cell minimum ride height 12" from the ground. No adjustable or sliding spacers.

Exhaust:

1. Racing mufflers mandatory.
2. If the track deems your race car to be too loud, you will be required to run track muffler.
3. 1 5/8" maximum underslung headers allowed stock manifolds no ram horn manifolds.

Glass:

1. All window glass (except for windshield) must be removed.
2. All broken glass must be removed from the car before it will be allowed to compete.
3. Quarter panel windows of clear Lexan construction are permitted.
4. No deflectors, or boxing of door opening area is permitted only Vent windows allowed maximum 12" length

Transmission:

1. Stock cast iron 3 speed.
2. All gears must be working.
3. Stock steel fly wheel Minimum 16 lbs. and stock clutch 30 lbs. total weight assembly.
4. Automatic transmissions allowed.
5. Stock torque converters only.

Rear End:

1. Locked rear ends allowed.
2. Mini spool or welded.
3. NO RACING BRACKETS ALLOWED.
4. No cambered rear ends.
5. 5:88 final drive ratio. 6. Stock for make. 9" **Ford** allowed.
7. Floaters Allowed.
8. No Quick-Change rears.
9. 100 lb penalty for W/5 hubs.

Radiator:

1. No anti-freeze allowed. Water and Keep Kool™ only.
2. All cars must have an overflow jug in working order.

Battery:

1. Battery may be moved to behind the driver's seat or remain in stock location

Brakes:

1. All cars must have four-wheel brakes in working condition.
2. Four wheel disc brakes allowed no clamp on brackets.
3. Stock Calipers.
4. After market pedals and master cylinders allowed.
5. No brake bias mechanisms allowed.

Communication:

1. Radios are allowed.
2. No cell phones allowed. Immediate Disqualification will result.

Spud Enduro Rules

Vehicle Types:

1. Vehicles must be street legal for make and model except for modifications made for racing allowed by these rules.
2. Passenger car vehicles only.
3. No convertibles, vans or full size trucks.
4. Mini 2wd trucks. S-10, Colorado, Ranger, Nissan, etc.
5. No leaf spring vehicles. Except mini trucks, that are factory equipped with rear leaf spring suspension.
6. No All Wheel Drives.

Engines:

1. 4 or 6 cylinder engines only.
2. Any stock engine and HP for year, make and model of car.
3. Forced induction (turbo, supercharged) allowed.

Wheel & Tires:

1. Wheel size open to stock sizes between 13" up to 20"
2. Maximum 7" wheel.
3. All wheel studs and lug nuts must be in place.
4. **NO RACING WHEELS.** Stock steel/or aluminum wheels only.
5. All wheels on the vehicle must be the same size and made of the same material.
6. Aftermarket steel wheels allowed, must be same width and offset as stock.
7. Tires may vary by one size side to side, for example: 175 on left and 185 on the right, but both tires on each side must be the same size.
8. No directional tires.
9. No recaps, 2-4 ply only.

10. No liquid filled. AIR ONLY.
11. Maximum allowable tread width of tires is 7". Tires must have minimum 380 tread wear.
 12. Volkswagen wheels allowed
 13. Buffing is allowed.
 14. No tire softener allowed.

Bumpers:

1. Bumpers must be at stock height for make and model of vehicle.
2. A bumper may be fabricated from thin wall square tubing but must mount to stock mounts or to round tubing slipped over and bolted to stock mounts.
3. All vehicles must have bumper covers to start the race.
4. Rear bumper/bumper covers should be strapped to body or frame to eliminate dragging.
5. Modified Enduro can run after market front and rear bumper covers, but must have stock bumper or replacement as noted above under it.
6. Bumper covers must match make of car.
7. A protection loop in front of the radiator may be added to the bumper, with one brace on each side attaching to the frame just in front of the radiator.

Weight:

1. Left side weight rule 54% of total weight maximum. No adding weight
2. Spud Speedway reserves the right to add any amount of weight to any location on any car to keep this class competitive and fun, Weight will be supplied and installed by owner. Installation must meet tech approval.

Windshield:

1. Front windshield must be in place when racing.
2. Windshield must be stock glass or Lexan™ may be used in place of glass for windshield, with 3 vertical windshield braces is allowed..
3. All other glass i.e. headlights and marker lights must be removed from the vehicle before it will be allowed to compete.
4. Rear side windows may be replaced with Lexan or sheet metal.

Body/Frame:

1. 5" ride height (Measured at the lowest point of the body or frame). Will be measured with driver in the seat with helmet.
2. All doors must be welded shut.
3. No body alterations allowed EXCEPT AS NOTED IN THIS SECTION.
4. All floor carpets and seats must be removed.
5. Roll bar or four-point cage with door bars is REQUIRED.
6. Dashboard may be removed for installation of roll cage only.
7. Steering column must remain stock.
8. Back of rear seat MUST be replaced with sheet metal.
9. Fenders may be trimmed one (1) inch for tire clearance.
10. No gutting of the interior metal except for installation of roll cage.

11. No gutting of hoods, trunks or inner fenders.
12. Hood and trunk lids must be on hinges.
13. Tech will determine if too much has been removed and may require re-installation.
14. Interior door panels may be removed for door bar and safety plate installation only. If an interior door panel is removed, there must be bars in that area that are attached to the roll cage.
15. No fiberglass body panels allowed.
16. If driver's doorplate is installed, it must be padded. .22 gauge
17. Drivers door padding recommended for all cars
18. Steel may be used to replace doors, as long as door appearance remains stock and stock door contours are followed.
19. Lexan Rub Rails Allowed

Battery:

1. The battery may be located in the OEM location or on the right side of the drivers' compartment. It must be secured in a non-conductive battery box bolted to the floorpan or secured in a battery tray. Battery cables must be insulated going through firewall.

Brakes:

1. All vehicles must have four-wheel brakes in proper working order, NO EXCEPTIONS.

Suspension:

1. 5 degree maximum wheel tilt on L/F and R/F only.
2. Rear wheels must remain within O.E alignment spec.
3. One spring rubber allowed per car.
4. No rear wheel tilt.
5. No cambered rear ends.
6. No lowering of the body on the frame.
7. Stock springs may be cut to achieve frame height.
8. Springs must be same size wire.
9. Sway-bar arrangement must be the same on both sides - stock length, with stock parts.
10. No adjustable shocks, no racing springs, no adjustable cups. Stock style upper control arm replacements may be used.
11. No angle type or offset type can be used.
12. Ball joints must be welded to control arm. *Recommend ball joints be "tack welded" to control arm with caution. Too much weld can cause premature ball joint failure.*
13. No spacers on top of struts.
14. All stock bump stops must be removed

Gears/Transmission:

1. All running gears must remain completely stock for model and generation of vehicle.
2. No 2 speed automatics.

- Rear End:** 1. Open rear ends only. NO LOCKED REARENDS. NO LOCKED FRONT ENDS. No posi-trac.
2. Rear End – O.E for make, model and year.

Exhaust:

1. Mufflers are mandatory.

Radiator:

1. No Anti-Freeze allowed. KEEP KOOL™ or water only.
2. Vehicles must have an overflow jug in working order.

Fuel Tanks:

1. Fuel cells and fuel tanks must be securely mounted in the trunk area.
2. No cutting of trunk floor to lower fuel cell/tank in car.
3. Boat Tanks must be in a canister of no less than .22-gauge steel.
4. May have a loop to protect fuel cell, plated and welded to trunk floor.

Safety:

1. A four-point roll cage is mandatory as explained/diagramed here in the rules package.
2. Anything not covered by any rules for this division shall remain stock as made by the manufacturer. Stock for year, make or model” of car must apply in all cases.

Seat:

1. **Factory driver’s seat may be used. It is highly recommended to use an aluminum Racing seat.**

Communication:

3. Absolutely no Scanners, Radios or Cell phones allowed. Immediate Disqualification will result.

MISCELLANEOUS:

1. Please remember the most important rule is “STOCK”. If you are unsure as to whether components are stock do not hesitate to contact Spud Speedway.
2. Any items suspected of being modified will be disallowed from competition. These cars will be subject to a preliminary inspection as well as a POST race inspection and may also be inspected for rule compliance at any time.
3. These rules cover all makes and models. STOCK means STOCK.

Spud Speedway Lights

Eligible Models:

This class will be limited to 4-cylinder front /rear wheel drive (FWD-RWD) cars with a stock wheel base for the make/model of the car. No Factory Production “Sports Cars” will be allowed.

Definition of a Factory 4-Cylinder Sports Car

A **Factory 4-Cylinder Sports Car** is defined as a **mass-produced, manufacturer-offered passenger vehicle** originally equipped with a **four-cylinder engine**, that includes **factory performance enhancements** specifically intended to improve handling, power, braking, and overall driving performance beyond standard base models.

Required Characteristics

To be classified as a **Factory 4-Cylinder Sports Car**, a vehicle must meet **all** of the following criteria:

1. Engine & Power

- Factory-installed **four-cylinder engine**
- Naturally aspirated or forced induction (turbocharged or supercharged)
- Manufacturer-rated horsepower significantly above the base model for that platform
- Engine must be a **factory option or factory special-edition configuration**

2. Factory Performance Package or Special Edition

The vehicle must be equipped **from the manufacturer** with one or more of the following:

- Sport-tuned or performance suspension
- Factory-installed limited-slip differential (mechanical or electronic)
- Performance-calibrated ECU or factory boost upgrade
- Larger or upgraded factory braking system
- Factory performance exhaust or intake components
- Performance-specific trim or badging identifying the model as a sport or performance variant

3. Suspension & Chassis

- Factory sport or performance suspension (lowered ride height, stiffer springs, upgraded dampers, sway bars, or adaptive suspension)
- Chassis tuning distinct from standard models intended for improved handling or track performance

4. Body & Aero (Factory Only)

- Factory-installed aerodynamic or performance body components such as:
 - Front splitters
 - Rear spoilers or wings
 - Side skirts
 - Functional air ducts or vents
- Cosmetic packages alone do **not** qualify unless paired with mechanical upgrades

5. Drivetrain

- Front-wheel drive, rear-wheel drive, no all-wheel drive permitted
- Manual or automatic transmissions allowed
- Transmission must be a factory offering for that model

Exclusions

The following do **not** qualify as Factory 4-Cylinder Sports Cars:

- Base models with only appearance packages
- Vehicles upgraded exclusively with aftermarket parts
- Economy or commuter models without factory performance enhancements
- Vehicles with engine swaps or non-factory forced induction

Examples of Qualifying Factory 4-Cylinder Sports Cars

(Examples only; eligibility subject to sanctioning body approval)

- Honda Civic Si / Type R
- Subaru WRX
- Toyota GR Corolla / GR86 (4-cyl)
- Hyundai Veloster N / Elantra N
- Volkswagen Golf GTI
- Mazda MX-5 (factory performance trims)
- Ford Focus ST

“Final determination of eligibility rests with the technical inspector or sanctioning body. Manufacturer documentation may be required to verify factory performance specifications.”

BODY:

1. Must be street legal for make and model, except for modifications made for racing allowed by these rules. Car is basically a street vehicle with all of the interior and glass removed. Original OEM glass windshield may be used. It must be secured in place with OEM type urethane. Slight cracks in the windshield may be accepted but will be at the discretion of the tech officials in the interest of safety. ALL exterior body panels must be OEM. No fabricated panels allowed.
2. Rear Side windows may be replaced with Lexan
3. A Lexan windshield will be allowed. It must have a minimum of three steel evenly spaced braces installed in windshield opening to right of driver.
4. Stock dashboards MAY be removed but the VIN tag MUST be retained.
Floor pan must be complete. Stock hood and trunk lids must be complete including hinges. Latches and lock cylinders must be removed. Two quick release pull type pins must be installed in both the hood and trunk lid.
5. Any aftermarket nose will be allowed provided in maintains a stock appearance. **Aftermarket, street/lms style bumper covers allowed. No dirt style nose allowed.** It will be subject to prior approval by the tech director.
6. Rust in body and unibody panels may be repaired provided that original metal thickness and dimensions are followed. Floorpan must be solid. No excess reinforcing beyond rust repair allowed. ANY cars with holes in floorpan or firewall

will not be allowed to compete. If vehicle structure is compromised by excessive rust, it will not be able to compete. (rotted out cars do not belong on a racetrack).

7. Driver's door AND PASSENGER DOOR must be welded or bolted shut. It is Recommended that the drivers inner door panel be removed in order to accommodate the curve of the roll cage shown in diagram.

8. The vehicle serial number (as seen through the lower left corner of the windshield) MUST be readable. Cars will not be allowed to compete if this number is not visible. This number will be recorded during inspection.

9. 5" ride height (Measured at the lowest point of the body or frame). Will be measured with driver in the seat with helmet.

MIRRORS:

1. One stock INSIDE mirror, to the right of the driver, with a maximum glass area of 24 sq. in. measured at the widest points is allowed. ONE EXTERIOR mirror will be allowed. It may be concave or convex with a maximum glass area of 16 sq.in. measured at the widest points.

ENGINE:

1. Must be stock for make/model.
2. Turbos allowed. Must be OEM for make, model and year.
3. NO superchargers. NO Rotary engines Absolutely NO Powertrain modifications. Transmission must be OEM stock for make and model. Only stock differential allowed. Differentials must not be locked.
4. The GM Ecotec 2.2 L61 will be allowed. This engine package will be closely monitored, and adjustments will be applied as necessary to ensure fair competition.
5. 200hp cap on engines.

TRANSMISSION:

1. Must be stock, unaltered for make/model. It may be a standard or automatic transmission.
2. No locked differentials allowed. LSD are allowed.

COOLING SYSTEM:

1. Radiator must be stock OEM type and mounted in stock position.
2. Water will be the only approved coolant. Absolutely no antifreeze.

EXHAUST:

1. Exhaust must follow SINGLE exhaust routing from engine to outlet. Exhaust must exit ahead of the LEFT or RIGHT rear wheel and not extend past the rocker panel.
2. A muffler or catalytic converter will not be required.

FUEL SYSTEM:

1. Stock carburetor / fuel injection system for that make and model.
2. Fuel system must remain stock and unaltered except for rust and safety repair.

3. No aftermarket fuel components (pumps, filters or injectors). No aftermarket ECM's, chips, ignition systems or ignition controllers will be allowed.
4. NO electronic throttle controllers on electronic throttle vehicles. (Includes but not limited to Pedal Commander, Sprint Booster, Injen, etc.)
5. Vehicle VIN must match ECM VIN. As an example if an engine is changed the VIN from the other car must match the ECM from that car.
6. Steel OEM type fuel lines will be used routed in stock locations. Rubber may only be used where the steel lines join to either the fuel metering device up front and the fuel tank in back. No COPPER line.
7. Must use the OEM in-tank electric fuel pump and be accessible from outside vehicle. It must be wired in series in the fuel pump electrical circuit to act as a safety shutoff of the fuel pump. Switch operation will be checked during pre-race inspection.
8. Regular unleaded fuel only. **No Race fuel.**

CHASSIS:

1. Complete chassis and suspension must be OEM stock for make, model and year. This includes struts, shocks, springs, swaybars, control arms, swaybar links, wheel hubs, and brakes.
2. No modification of any part of the car for performance or handling (unless specifically stated)
3. No modification of stock suspension locating points allowed except for those listed below:
 - Strut mounting holes may be modified for camber adjustment only. NO cutting or grinding of spindle
 - **Maximum wheel camber will be 5 degrees. Wheel Tilt allowed on all 4 wheels**Struts MUST be OEM replacement types. This includes the KYB Excel-G. No other performance types such as Koni, Bilstein, KYB AGX, will be allowed.
4. Springs must be stock. No cut coil springs.

STEERING:

1. All components must remain stock for make, model, and year. Padding on steering wheel is required. Steering wheel disconnects are allowed.
2. The steering columns used on the Cobalt, G5/Pursuit, and Ion have electric assist. This column may be modified to manual if required.

TIRES:

1. Wheel size must be between 13"-20" OEM for steel wheels and be the SAME DIAMETER SIDE TO SIDE.
2. OEM tire series may include 60, 65, 70, and 75. OEM section widths may include 185, 195, 205, and 215.
3. Tires will be limited to the following UTOQ ratings on the sidewall. Treadwear must be no less than 400 and traction must be minimum A (No AA) Numbers on sidewall must be readable. Any numbers that cannot be read will be deemed illegal.
4. OEM aluminum wheels will be allowed. (If we see failures of aluminum rims we may require a steel rim or racing wheel, but only if we deem it necessary for spectator safety)
5. They will be 14" or 15" with a maximum width of 7" and a minimum backspace of 4". In addition, 1" lug nuts with a 45° taper and extended length wheel studs will be required.
6. At a minimum the wheel studs must be flush with the wheel nut. These wheels may stick out past the fender so clearance must be carefully checked.

7. A Bassett race wheel is recommended for this class.

ROLL CAGE:

1. A 4-point roll cage is mandatory. Roll bar piping must meet a Minimum of 1 3/4" diameter x 0.095 thickness roll bar tubing. Roll cage is to consist of the following: Four upright pipes at the corners of cage. The front uprights are to be angled rearward to meet "halo" at the top of cage near top of "A" pillars.
2. The rear uprights will join the halo and will be used to anchor the seat back. The pipes must be welded to 6" x 6" x 3/16" plates located above and below the floorpan of the car. This will form the main perimeter of the cage. Driver's side of cage must have three (3) parallel mounted bars connecting two uprights at top of door and one at floor level.
3. The parallel bars are to be secured by several upright pipes welded between the parallel bars. They are to be placed a minimum of 12" apart. The inner door panel may be removed and the piping moved out slightly into door to give more clearance between driver and left side of cage. There is to be a bar joining the front uprights from side to side at dash height.
4. The passenger side of the cage is to consist of one parallel and one diagonal bar between the front and rear uprights. Rear of the cage is to consist of a horizontal bar connecting the bottom of the uprights for lateral cage strength.
5. The other bar is to be used to secure the seat back. All welds must be professional. Welded gussets are highly recommended. The roll cage piping should be padded close to the driver.
6. Closely following the text and the attached drawing in rules will assist in accurate construction of this cage assembly.
7. Two bars may be added to the roll cage rear halo or rear uprights and extend to the trunk floor pan. They must be welded to plates at the floor pan. The bars may be crossed or X braced. (See diagram)

BATTERY:

1. The battery may be located in the OEM location or on the right side of the drivers' compartment. It must be secured in a non-conductive battery box bolted to the floorpan or secured in a battery tray. Battery cables must be insulated going through firewall.

FUEL TANK:

1. Stock mounted in stock location, skid plate recommended. If mounted in car, fuel cell is required.
2. No stock tanks inside of car.
3. All cars that have installed the fuel tank in the trunk must seal off passenger compartment with sheet metal. NO EXCEPTIONS. This is not an area to skimp. Please ensure fuel cell installation is completely safe and secure. Contact tech for clarification if unsure of setup.

BRAKES:

1. ALL wheel brakes MUST operate or car will NOT be allowed to compete. No air ducts allowed.
2. Brake performance will be checked to ensure proper operation.

WEIGHT:

1. 55% left only

2. Weight will be added to maintain a minimum total weight as well as percentage of weight. The weight is to be bolted to the floor pan area with a minimum of grade 5 bolts. Plate or large washers may be required to prevent bolt pull through.
3. Weight may consist of lead or metal blocks or plate NOT to exceed 25 lb. per block or plate. Weight MUST be safely and securely fastened. Weight mounting will be subject to tech approval.
4. All cars will maintain a rear percentage of 36% maximum. These weights and percentages will be monitored and may be adjusted to ensure fair competition.
5. Spud Speedway reserves the right to add any amount of weight to any location on any car to keep this class competitive and fun, Weight will be supplied and installed by owner. Installation must meet tech approval.

COMMUNICATION:

1. Absolutely no Scanners, Radios or Cell phones allowed. Immediate Disqualification will result.

MISCELLANEOUS:

4. Please remember the most important rule is "STOCK". If you are unsure as to whether components are stock do not hesitate to contact Spud Speedway.
5. Any items suspected of being modified will be disallowed from competition. These cars will be subject to a preliminary inspection as well as a POST race inspection and may also be inspected for rule compliance at any time.
6. These rules cover all makes and models. STOCK means STOCK.

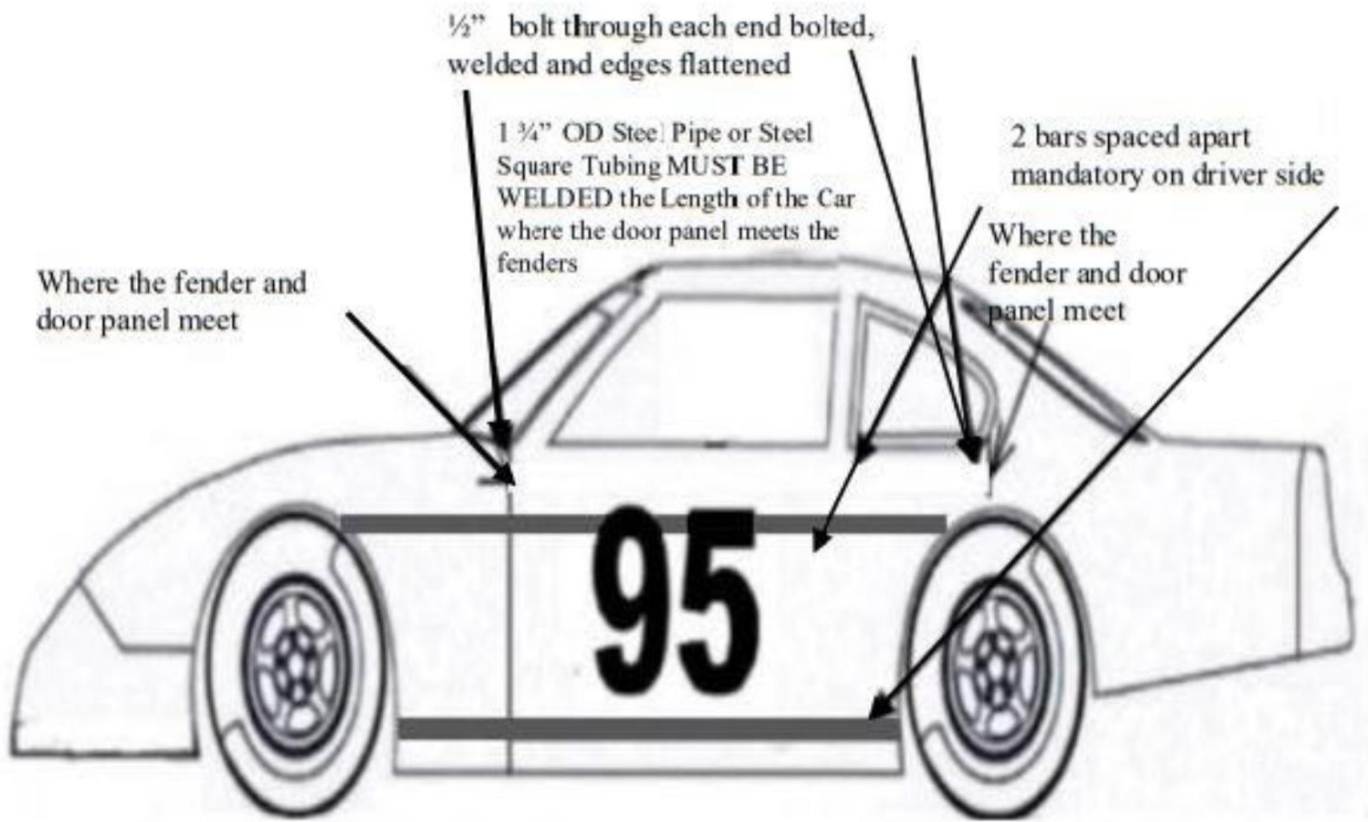

Driver Side Mandatory –
 Passenger side suggested but NOT Mandatory

Roll Cages

1. A four-point roll cage is mandatory in All Divisions. If roll cage is used it must be approved by safety. A roll cage must consist of four uprights joined together at all four corners at the top. Tubing must be at least 1 ½" Round O.D. and minimum .090 wall thickness. All roll cages must be professionally welded.
2. An "X" must be placed between the rear uprights, or a horizontal bar may be used to join the two rear uprights at the bottom, with a diagonal bar joining the top and bottom horizontal bars.
3. Four bars running between front and rear uprights are required on the driver's side. These bars must be padded.
4. A minimum of three horizontal bars or an "x" is required on the passenger side of the vehicle.
5. A horizontal bar between the two front uprights just above or below the dashboard is required.
6. Forward or rearward bars attached to the main uprights are NOT allowed.
7. The roll cage may not reinforce the body or frame or alter the geometry of the vehicle.
8. Roll bars may NOT extend through firewalls.
9. All vehicles with frames must have the roll cage welded directly to the frame NOT the floorboards.
10. All vehicles without frames must use the sandwich method shown in the roll cage diagram to secure the roll cage to the vehicle.
11. May have rearward bars no further than firewall or center of strut towers.
12. Drivers door padding is required.

SUGGESTED ROLL CAGE DESIGN

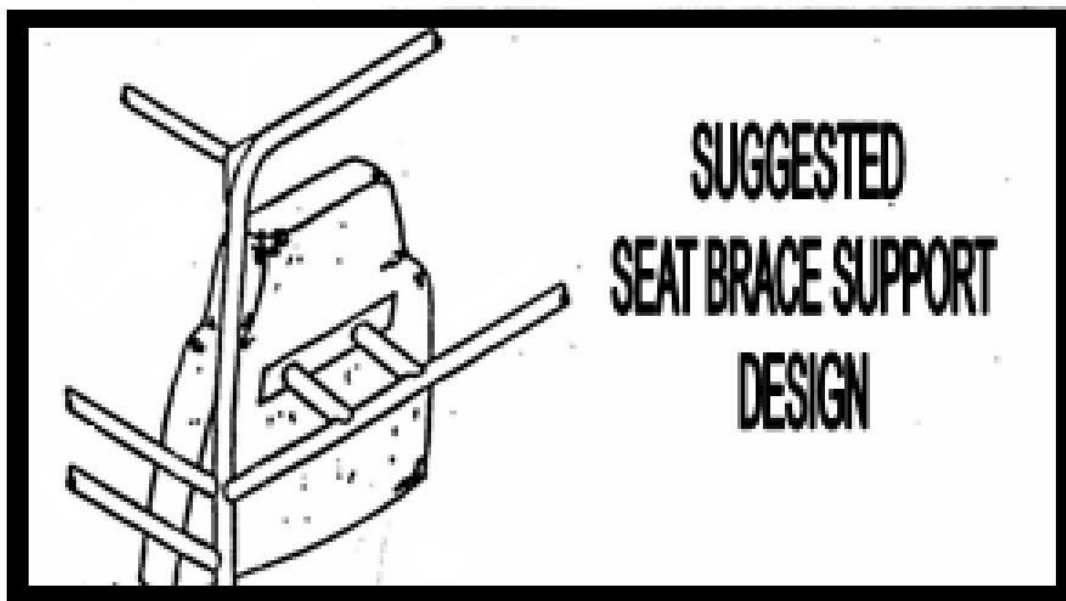
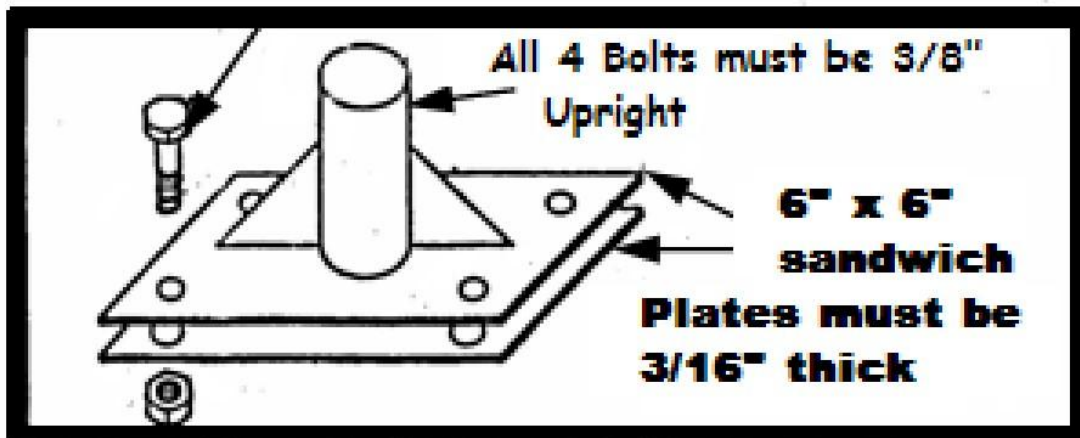
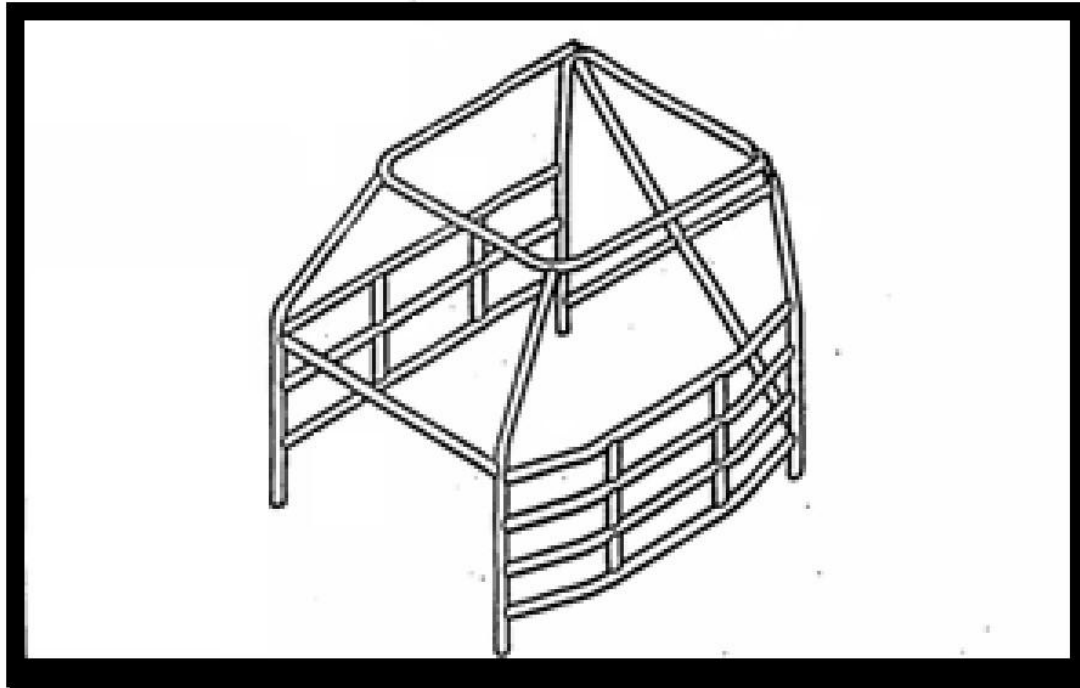

Seat Belt Installation

Recommended Seat Belt Installation

